

# **Flam**<sup>®</sup>

**Isıtma Teknolojisi**

## User Manuel

SC.10... HME

SC.12... HME

SC.14... HME

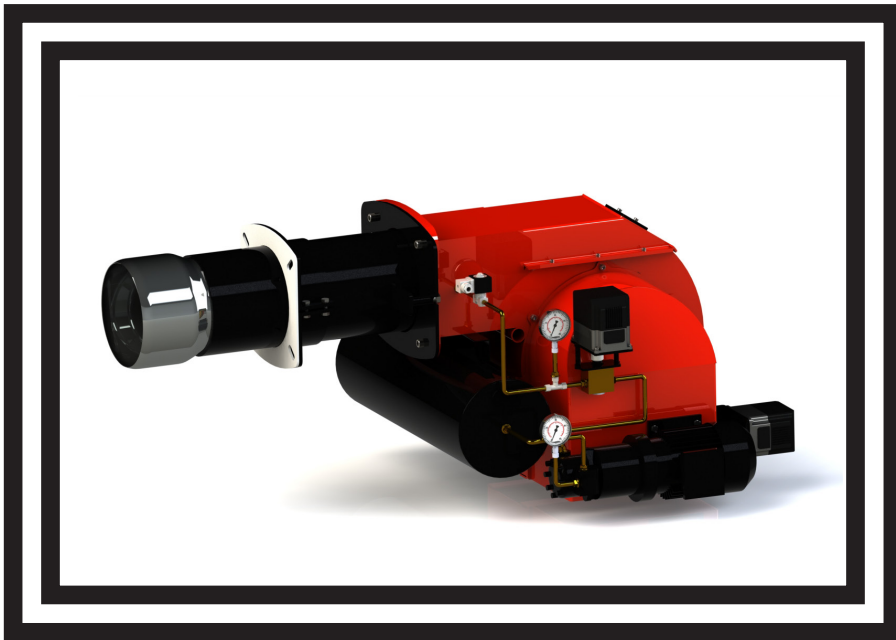

**Heavy Oil  
Burner**

**English**

This Manual published in  
27/11/17

**This manual includes technical information for devices below :**

**SC 10.1 HM - 850 – 2750 kW**

**SC 10.2 HM - 950 – 3200 kW**

**SC 10.3 HM - 950 – 4000 kW**

**SC 12.1 HM - 1100 – 4300 kW**

**SC 12.2 HM - 1250 – 5000 kW**

**SC 14.1 HM - 1400 – 6500 kW S**

**C 14.2 HM - 1800 – 7800 kW**

-Before using the burner for the first time please carefully read the chapter “WARNINGS NOTES FOR THE USER : HOW TO USE THE BURNER SAFELY” in this instruction manual, which is an integral and essential part of the product. The works on the burner and on the system have to be carried out only by competent people.

-Read carefully the instructions before starting the burner and service it.

-The system electric feeding must be disconnected before starting working on it.

-If the works are not carried out correctly it is possible to cause dangerous accidents.

### Statement of Conformity

We hereby declare under our own responsibility, that our “CE” marked products Series:

### Description:

domestic and industrial blown air burners fired by gas, oil and dual fuel respect the minimal regulation of the

European Directives:

•90/396/EEC (G.A.D)

•92/42/EEC (B.E.D)

•89/336/EEC (E.M.C. Directive)

•73/23/EEC (Low Voltage Directive)

•98/37 EEC (Machinery Directive)

and have been designed and tested in accordance with the European Standards:

•EN 676 (gas and dual fuel, gas side)

•EN 267 (light oil and dual fuel, oil side)

-EN 60335-1:2001+A1:2004+A11:2004 +A2:2006

-EN 60335-2-102:2006

-EN 50165:1997:A1:2001

-EN 55014-1:2000 + A1:2001+A2:2002

-EN 55014-2:1997 + A1:2001

-EN 50366:2004 + A1:2006

-EN 61000-3-2:2000 + A2:2005

Surveillance accordingly Gas Appliances Directive 0/396/EEC made by: CE2159 S&Q MART

### WARNING NOTES FOR THE USER HOW TO USE THE BURNER SAFELY FOREWORD

These warning notes are aimed at ensuring the safe use of the components of heating systems for civil use and the production of hot water. They indicate how to act to avoid the essential safety of the components being compromised by incorrect or erroneous installation and by improper or unreasonable use. The warning notes provided in this guide also seek to make the consumer more aware of safety problems in general, using

necessarily technical but easily understood language. The manufacturer is not liable contractually or extra contractually for any damage caused by errors in installation and in use, or where there has been any failure to follow the manufacturer's instructions.

### GENERAL WARNING NOTES

•The instruction booklet is an integral and essential part of the product and must be given to the user. Carefully read the warnings in the booklet as they contain important information regarding safe installation, use and maintenance. Keep the booklet to hand for consultation when needed.

•Equipment must be installed in accordance with current regulations, with the manufacturer's instructions and by qualified technicians. By the term „qualified technicians' is meant persons that are competent in the field of heating components for civil use and for the production of hot water and, in particular, assistance centres authorised by the manufacturer. Incorrect installation may cause damage or injury to persons, animals or things. The manufacturer will not in such cases be liable.

•After removing all the packaging make sure the contents are complete and intact. If in doubt do not use the equipment and return it to the supplier. The packaging materials (wooden crates, nails, staples, plastic bags, expanded polystyrene, etc.) must not be left within reach of children as they may be dangerous to them. They should also be collected and disposed on in suitably prepared places so that they do not pollute the environment.

•Before carrying out any cleaning or maintenance, switch off the equipment at the mains supply, using the system's switch or shut-off systems.

•If there is any fault or if the equipment is not working properly, de-activate the equipment and do not attempt to repair it or tamper with it directly. In such case get in touch with only qualified technicians. Any product repairs must only be carried out by Flam authorised assistance centres using only original spare parts. Failure to act as above may jeopardise the safety of the equipment. To ensure the efficiency and correct working of the equipment, it is essential to have periodic maintenance carried out by qualified technicians following the manufacturer's instructions.

•If the equipment is sold or transferred to another owner or if the owner moves and leaves the equipment, make sure that the booklet always goes with the equipment so it can be consulted by the new owner and/or installer.

•For all equipment with optionals or kits (including electrical), only original accessories must be used.

### BURNERS

•This equipment must be used only for its expressly stated use: applied to boilers, hot air boilers, ovens or other similar equipment and not exposed to atmospheric agents. Any other use must be regarded as improper use and hence dangerous.

•The burner must be installed in a suitable room that has ventilation in accordance with current regulations and in any case sufficient to ensure correct combustion

•Do not obstruct or reduce the size of the burner air intake grills or the ventilation openings for the room where a burner or a boiler is installed or dangerous mixtures of toxic and explosive gases may form.

•Before connecting the burner check that the details on the

plate correspond to those of the utility supplies (electricity, gas, light oil or other fuel).

- Do not touch hot parts of the burner. These, normally in the areas near to the flame and any fuel pre-heating system, become hot when the equipment is working and stay hot for some time after the burner has stopped.
- If it is decided not to use the burner any more, the following actions must be performed by qualified technicians:
  - a) Switch off the electrical supply by disconnecting the power cable from the master switch.
  - b) Cut off the fuel supply using the shut-off valve and remove the control wheels from their position.
  - c) Render harmless any potentially dangerous parts.

### **Special warning notes**

- Check that the person who carried out the installation of the burner fixed it securely to the heat generator so that the flame is generated inside the combustion chamber of the generator itself.
- Before starting up the burner, and at least once a year, have qualified technicians perform the following operations:
  - a) Set the burner fuel capacity to the power required by the heat generator.
  - b) Adjust the combustion air flow to obtain combustion yield of at least the minimum set by current regulations.
  - c) Carry out a check on combustion to ensure the production of noxious or polluting unburnt gases does not exceed limits permitted by current regulations.
  - d) Check the adjustment and safety devices are working properly.
  - e) Check the efficiency of the combustion products exhaust duct.
  - f) Check at the end of the adjustments that all the adjustment devices mechanical securing systems are properly tightened.
  - g) Make sure that the use and maintenance manual for the burner is in the boiler room.

### **ELECTRICAL SUPPLY**

- The equipment is electrically safe only when it is correctly connected to an efficient ground connection carried out in accordance with current safety regulations. It is necessary to check this essential safety requirement. If in doubt, call for a careful electrical check by a qualified technicians, since the manufacturer will not be liable for any damage caused by a poor ground connection.
- Have qualified technicians check that the wiring is suitable for the maximum power absorption of the equipment, as indicated in the technical plate, making sure in particular that the diameter of cables is sufficient for the equipment's power absorption.
- Adapters, multiple plugs and extension cables may not be used for the equipment's power supply.
- An omnipolar switch in accordance with current safety regulations is required for the mains supply connection.
- The electrical supply to the burner must have neutral to ground connection. If the ionisation current has control with neutral not to ground it is essential to make a connection between terminal 2 (neutral) and the ground for the RC circuit.
- The use of any components that use electricity means that certain fundamental rules have to be followed, including the following:
  - do not touch the equipment with parts of the body that are wet or damp or with damp feet

-do not pull on electrical cables

-do not leave the equipment exposed to atmospheric agents (such as rain or sun etc.) unless there is express provision for this.

-do not allow the equipment to be used by children or inexperienced persons.

- The power supply cable for the equipment must not be replaced by the user. If the cable gets damaged, switch off the equipment, and call only on qualified technicians for its replacement.

- If you decide not to use the equipment for a while it is advisable to switch off the electrical power supply to all components in the system that use electricity (pumps, burner, etc.).

### **GAS, LIGHT OIL, OR OTHER FUEL SUPPLIES**

- Installation of the burner must be carried out by qualified technicians and in compliance with current law and regulations, since incorrect installation may cause damage to person, animals or things, for which damage the manufacturer shall not be held responsible.
- Before installation it is advisable to carry out careful internal cleaning of all tubing for the fuel feed system to remove any residues that could jeopardise the proper working of the burner.
- For first start up of the equipment have qualified technicians carry out the following checks:
  - If you decide not to use the burner for a while, close the tap or taps that supply the fuel.

### **FLUES FOR HIGH EFFICIENCY BOILERS AND SIMILAR**

It should be pointed out that high efficiency boilers and similar discharge combustion products (fumes) at relatively low temperatures into the flue. In the above situation, traditional flues (in terms of their diameter and heat insulation) may be suitable because the significant cooling of the combustion products in these permits temperatures to fall even below the condensation point. In a flue that works with condensation there is soot at the point the exhaust reaches the atmosphere when burning light oil or heavy oil or the presence of condensate water along the flue itself when gas is being burnt (methane, LPG, etc.). Flues connected to high efficiency boilers and similar must therefore be of a size (section and heat insulation) for the specific use to avoid such problems as those described above.

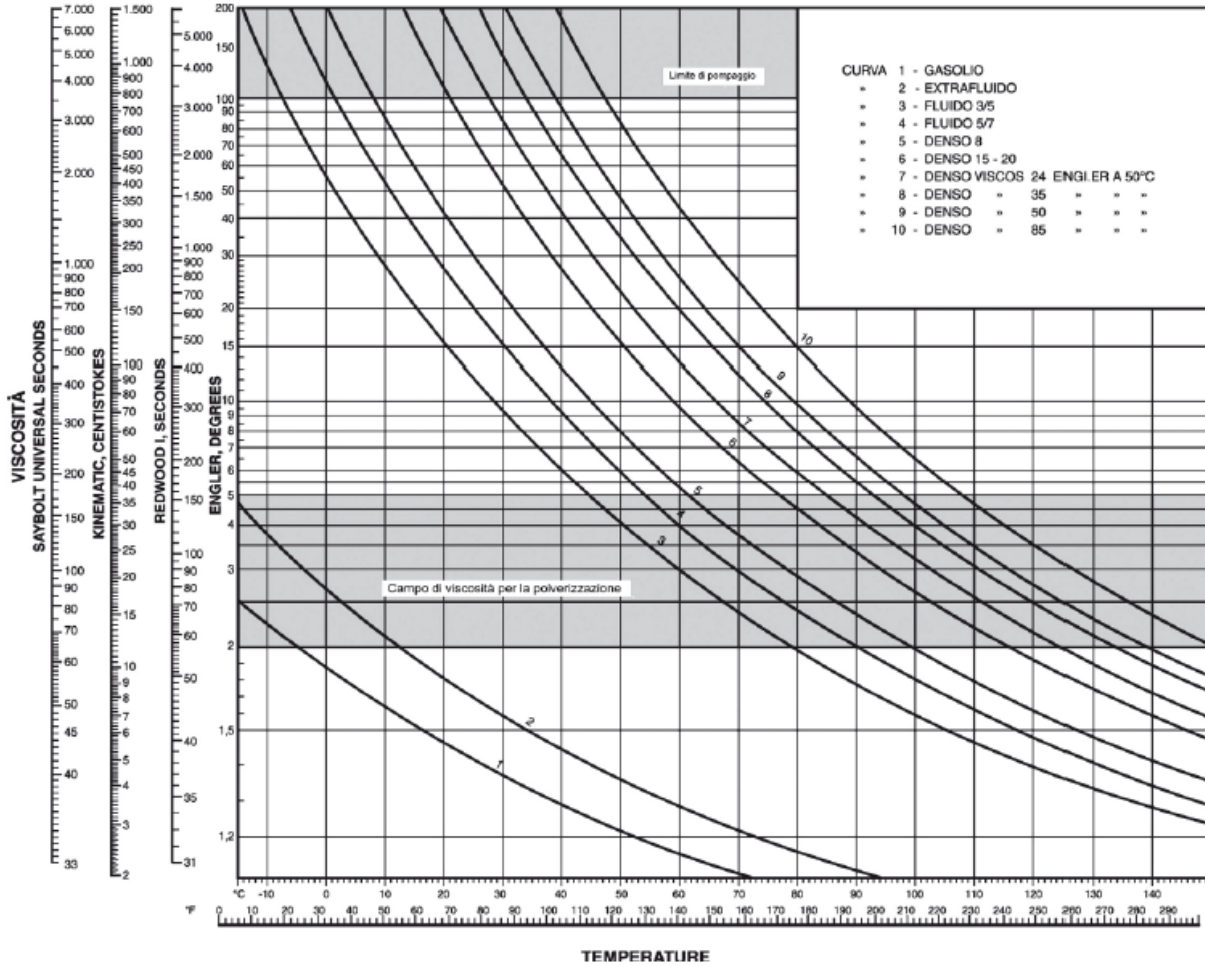

**Dimensions**

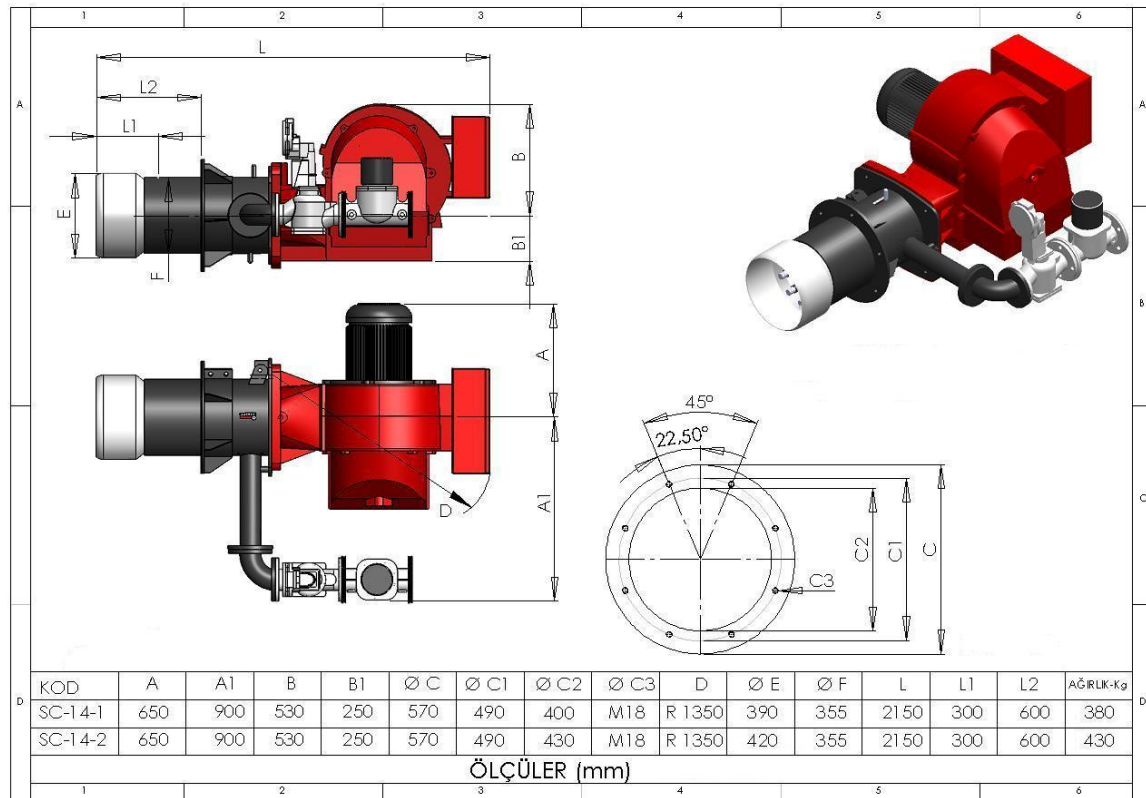
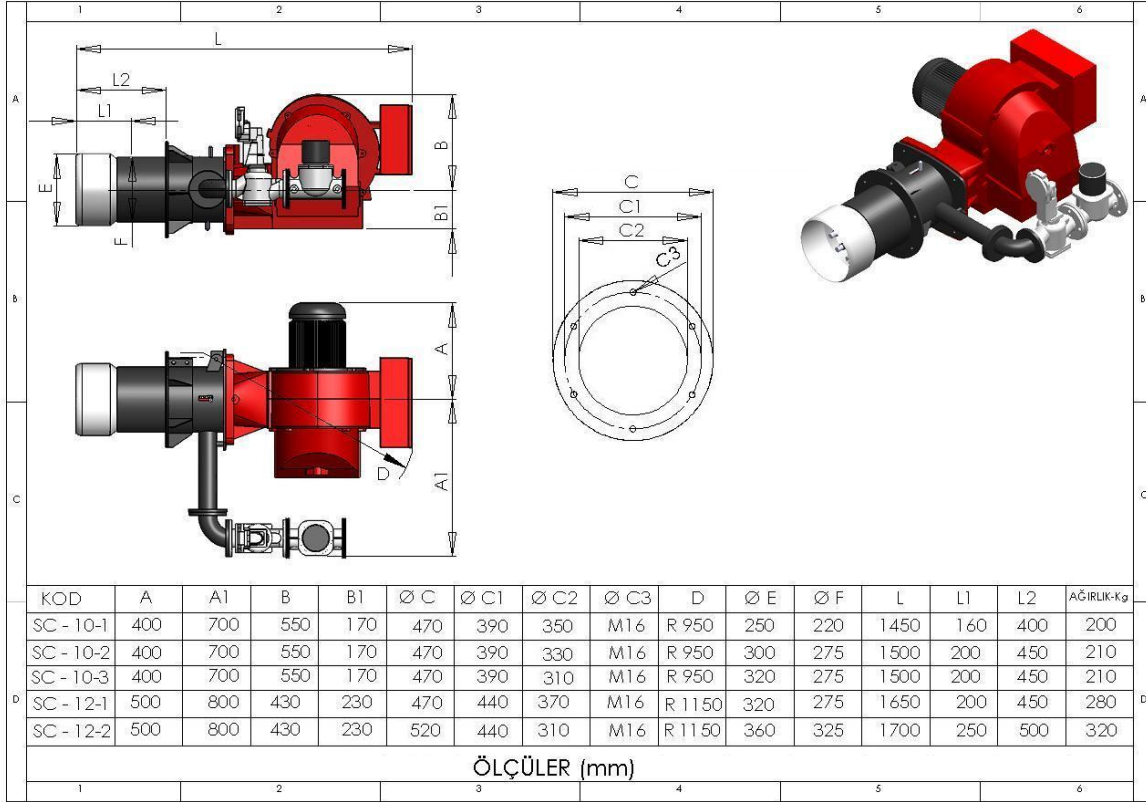

TECHNICAL SPECIFICATIONS			BURNER MODEL						
			SC 10.1 HM	SC 10.2 HM	SC 10.3 HM	SC 12.1 HM	SC 12.2 HM	SC 14.1 HM	SC 14.2 HM
THERMIC CAPACITY	MAX	kW	2700	3200	3750	4300	5000	6500	7800
	MIN	kW	650	850	950	1100	1250	1400	1800
FLOW RATE	MAX	kg/h	227	270	316	362	421	548	657
	MIN	kg/h	55	72	80	93	105	118	152
VOLTAGE		VOLT	3 N ~ 400 V 50 Hz						
FAN MOTOR	kW		4 + 2.2	5.5 + 2.2	5.5 + 2.2	7.5 + 3	11 + 3	18.5 + 3	
	rpm		2800	2800	2800	2800	2800	2800	2800
BURNER SEQUENCE CONTROLLER			SIEMENS LAL 1.25						
IGNITION TRANSFORMER			15 kV 30 mA						
FLAME CONTROL			PHOTORESISTANCE						
SAFETY TIME			5 SN.						

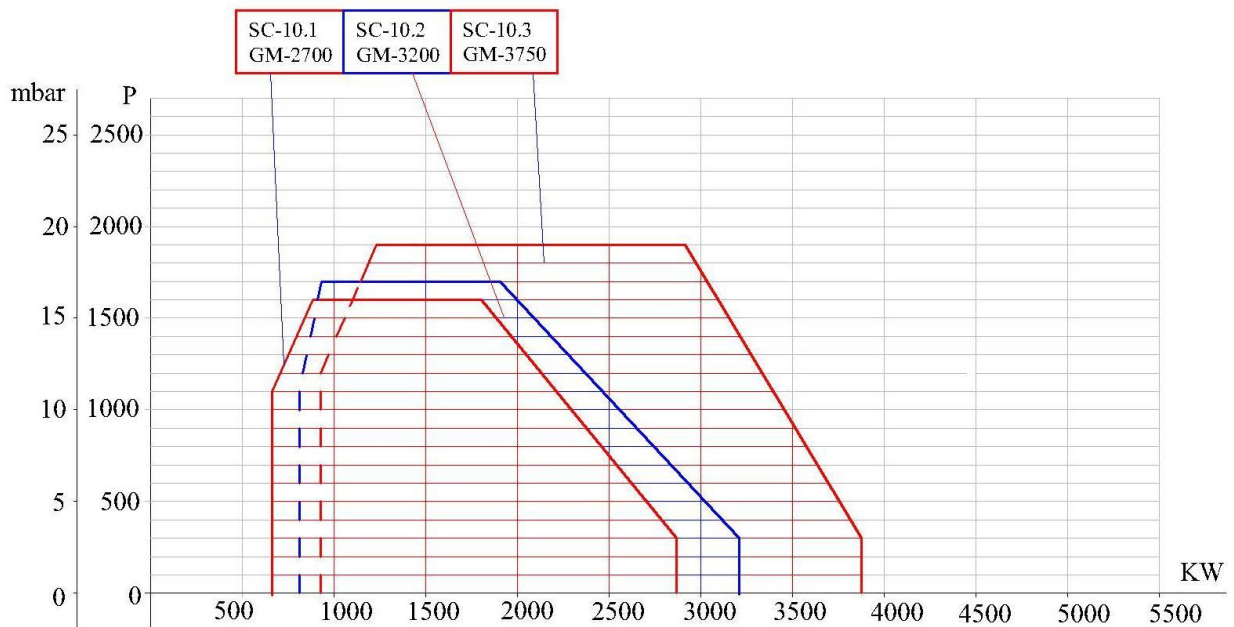

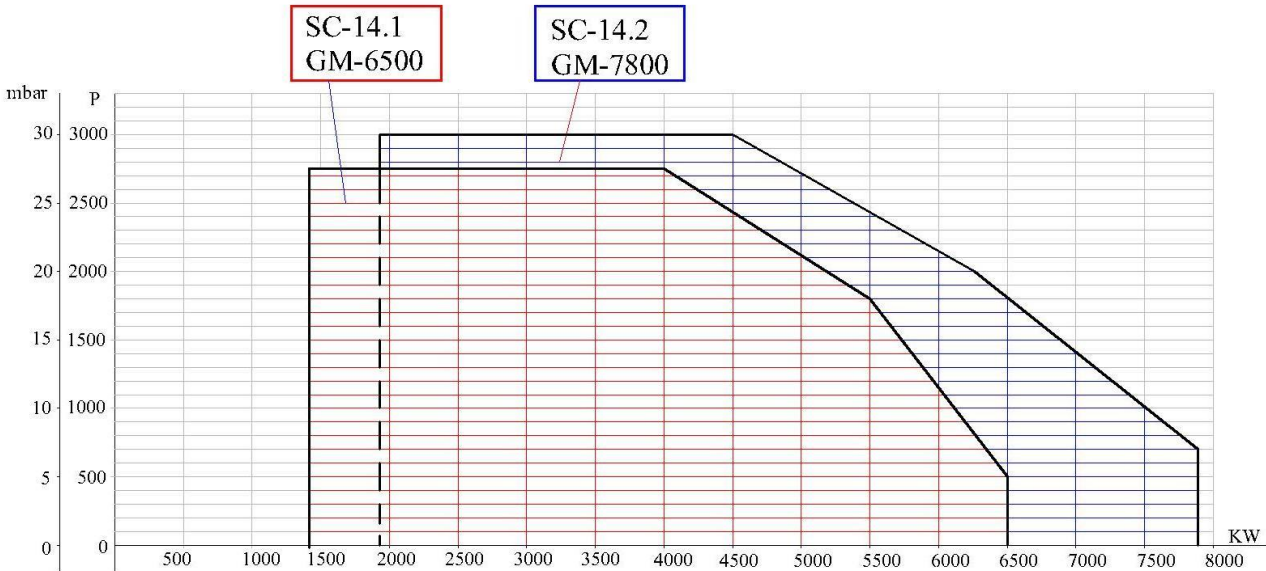
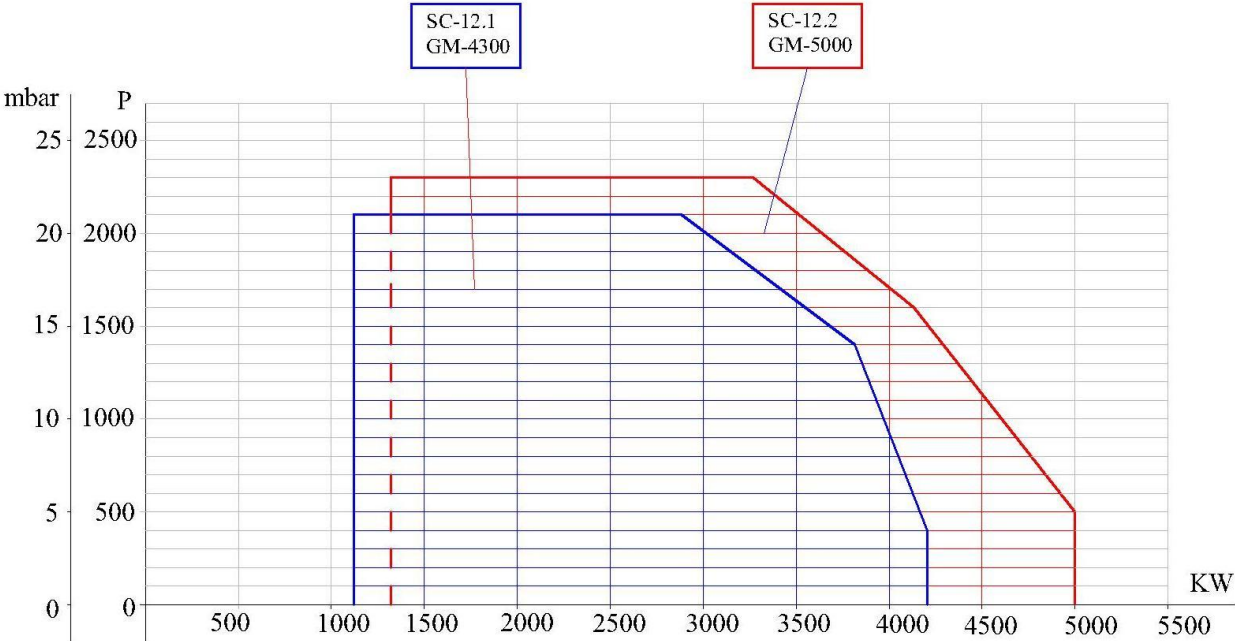

## FASTENING THE BURNER TO THE BOILER

1. Be sure the boiler plate has been drilled fit to burner pipe diameter.
2. Screw and tighten the pins into boiler plate. Fixing bolt : sabitleme civatası
3. Set apart the combustion head from the burner pipe.
4. Plug the gasket and burner flange to boiler plate.
5. Attach a washer and threaded nut to every pin. Do not tighten.
6. Dismount the both of bolts on flange.
7. Hold the burner safely and insert the burner pipe into flange. ATTENTION: Burner must be lifted up by a lever. Manpower should not be used for lifting. Any mistake during lifting may cause serious injuries or die.
- NOTE: Keep in mind that burner pipe must be penetrated into combustion chamber as recommended by boiler manufacturer.
8. Push the burner pipe into boiler plate and balance the burner.
9. Mount the both of bolts on flange.
10. Tighten the pins on stud which fix the flange to boiler.
11. Open the boiler plate and mount the combustion head to burner pipe. Fill the space between boiler plate and burner pipe with rock-wool heat insulating material.

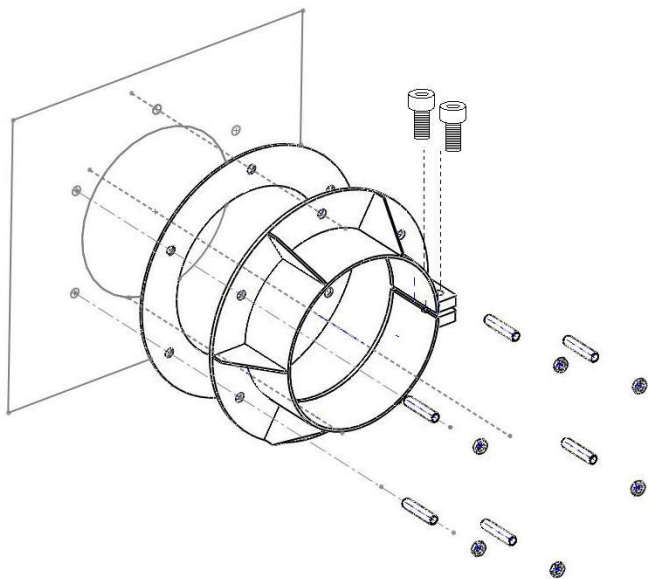

## REQUIREMENTS FOR A PROPER INSTALLATION

Before proceeding with installation make certain that:

- 1) The chimney (cross-section and height) is suitable for the boiler in question. Nevertheless, the following considerations are always useful:
  - a) the boiler-chimney duct must be very short and arranged in an accentuated rise towards the chimney;
  - b) sheet metal external chimneys, without suitable insulating coating, are not recommended as they could cause condensation as well as soot at the outlet. Moreover, the low temperature existing in these chimneys cannot ensure a good air draft;
  - c) there must not be any air infiltration along the entire length of the flue pipe;
  - d) the top must be free from any contiguous obstacles and the cowl be placed in such a way as to allow free outlet of combustion gases;
  - e) for mountain locations, the chimney section must be increased by 10% for every 500 meters of altitude above sea level;

f) circular or square sections with rounded corners are to be preferred; when using rectangular sections the ratio between the large and small sides must never exceed 1.5.

g) bear in mind that by increasing the height above sea level, the air becomes more rarefied, thus reducing the efficiency of the burner fan. As a consequence, the burner maximum rated output is also reduced (approximate values are given in the table below).

Altitude above sea level in meters Consequent reduction in rated output (%)

1000 m - 6%

1500 m - 11%

2000 m - 16%

2500 m - 21%

3000 m - 27%

3500 m - 32%

2) When installation of a refractory coating is required in the combustion chamber (when required by type of boiler), the material must be arranged around the burner combustion head in accordance with the instructions given by the boiler manufacturer.

3) The burner power supply must be arranged as indicated in our diagram and the electrical connections on the burner have been prearranged for the mains voltage.

4) The fuel piping must be arranged according to our diagrams.

5) Make certain that the nozzle has the proper characteristics for the furnace. If not replace with a suitable one. In no case should the amount of fuel supplied be greater than the maximum required by the boiler and the maximum allowed for the burner. Ascertain that the nozzle spray angle is adequate to avoid problems (flickering flame, disk and combustion head fouling, violent start-ups, etc.). If such problems do occur, the nozzle must be replaced with another one whose angle of spray is suitable for the case. Obviously the fuel supply must never exceed the maximum allowed for the boiler.

6) Make certain that the burner head penetrates into the combustion chamber according to the instructions of the boiler manufacturer.

## REFRACTORY COATING

The coating the combustion chamber with refractory material allows a very high temperature around the flame, thus facilitating combustion. In addition, it also protects the unbathed parts of the boiler.

It is advisable to use good quality refractory material which can resist temperatures in excess of 1500°C (42 ÷ 44% alumina).

Avoid the following:

- a) Never use an excessive lining as this is always insulating, decreasing the heat exchange and hence boiler performance;
- b) Never use an arrangement which appreciably reduces the furnace volume as this hinders good combustion because of insufficient space.

Remember that, today, boiler manufacturers tend to avoid installing a refractory lining. In all cases, the boiler manufacturer's instructions for the execution of the refractory coating must be followed to the letter. Arrangement of refractory material, if any, around the combustion burner opening should be made in agreement with the constructor of same.



## ELECTRIC CIRCUITS

It is advisable that all electric connections be carried out with flexible cable. The three-phase line, with neutral, of adequate size for burner power consumption, must have a circuit breaker with fuses located in the thermal power plant near the burner. All electric lines should be protected with sheathing and pass far away from any high-temperature parts.

Ensure that the voltage and frequency of the available electrical energy be adequate for the burner. For further details refer to the specific wiring diagrams.

## FUEL SUPPLY SYSTEM

The burner pump must receive fuel from a suitable supply circuit, including an auxiliary pump with pressure adjustable from 0,5 to 2 bar. Fuel must be pre-heated to 50 ÷ 60° C.

The supply pressure value of the fuel at the burner pump (0,5 ÷ 5 bar) must not vary either when the burner is not in operation or when it is operating at the maximum level fuel supply called for by the boiler.

Pipe dimensions depend on their length and the capacity of the pump being used.

Our instructions only regard what is necessary for ensuring good operation.

The regulations to be observed in order to comply with anti-smog laws as well as the local Firemen's regulations, should be referred to in the relevant publications.

## BURNER CONTROL PANEL

A control panel has been provided with burner which supplies operating the system automatic and manually in possible cases. PID control device and connected temperature or pressure sensor operates the burner in accordance with requirements of system. Turn the AUTO-MAN selector to AUT position to establish PID control

visually; suitable for the burner.

3) Check that there is water in the boiler and that the system's gate valves are open.

4) Check, with absolute certainty, that the discharge of combustion products can take place freely (boiler and chimney lock-gates should be open).

5) Make sure that the voltage of the electric line to which the burner is to be connected, corresponds to that requested by the manufacturer, and that the motor's electrical connections have been correctly prepared to match the voltage rating available. Also are in accordance with our electric wiring diagram.

6) Make sure that the combustion head enters the furnace to the extent specified by the boiler manufacturer. Check that the combustion head is in the position considered necessary for the fuel delivery required (the air passage between the disk and the head should be considerably closed when the fuel delivery is relatively reduced; on the other hand, when the nozzle has a fairly high delivery, the air passage between the disk and the head should be relatively (see chapter "Regulation of the combustion head").

7) Remove the protective cover from the rotating disk inserted on the modulating motor. On this disk have been fitted adjustable screws which are used to control the fuel and the relative combustion air.

8) Put the two modulating switches in the "MIN" (minimum) and "MAN" (manual) positions.

9) Start up the fuel supply auxiliary circuit, check its efficiency and regulate the pressure at about 1 bar (if the circuit is supplied with a pressure regulator).

10) Remove from the pump the vacuummeter connection point plug and then open slightly the gate valve fitted on the fuel arrival pipe. Wait until fuel comes out of the hole, without air bubbles, and then re-close the gate valve.

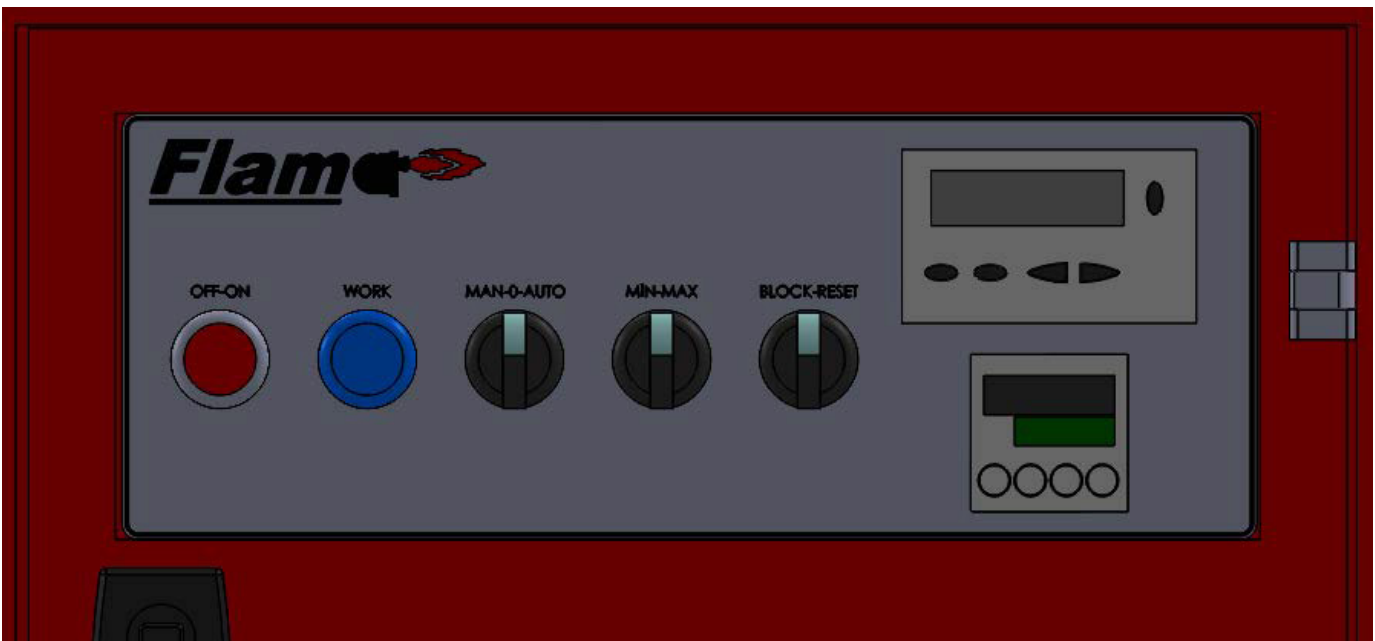

## STARTING UP AND REGULATION WITH HEAVY OIL

1) Check that the characteristics of the nozzle (delivery and spray angle) are suitable for the furnace. If not, replace it.  
2) Check that there is fuel in the cistern and that it is, at least

11) Insert a manometer (end of the scale about 3 bar) into the vacuummeter connection point on the pump and control the value of the pressure at which the fuel arrives at the burner pump. Insert a manometer (and of the scale about 30 bar) into the

manometer connection point provided on the pump and control its working pressure. Insert a manometer (end of the scale about 30 bar) into the special connection point of the first flame return pressure.

12) Now open all the gate valves and any other fuel interception devices fitted on the fuel pipelines.

13) Put the switch on the control panel in the "0" (open) position and give current to the electric lines which the burner is connected to. Check, by pressing manually on the relative relay, that the motor rotates in the right direction. If it does not, exchange the places of two cables of the principle line in order to invert the sense of rotation.

14) Start operating the burner pump by pressing manually on the relative relay until the manometer, which measures the working pressure of the pump, indicates a slight pressure. The presence of low pressure in the circuit confirms that filling up has taken place.

15) Insert the switch on the control panel to give current to the control box.

If the thermostats (safety and boiler) are closed, the control boxes programmer will be connected and will insert the burner's component devices according to its established programme. The unit starts up in this way, as described in chapter "Description of Operations".

16) When the burner is operating at "minimum", proceed with regulating the air to the quantity considered necessary to ensure efficient combustion. Tighten or loosen the adjusting screws situated on the point of contact on the lever, which transmits the movement to the combustion air regulation shutter. It is preferable that the quantity of air for the "minimum" is slightly reduced, in order to ensure a soft ignition even in the most critical conditions.

17) After having regulated the air for the "minimum", put the modulation switches in the "MAN" (manual) and "MAX" (maximum) positions.

18) The modulation motor starts moving; wait until the disk on which the regulating screws have been fitted, has reached an angle of about 12° (this corresponds to the space taken up by three screws), stop the modulation motor and return the switch to the "0" position. Carry out a visual control of the flame and proceed, if necessary, with regulating the combustion air by operating as described in point 16. Subsequently, control combustion with the appropriate instruments and modify, if necessary, the previous regulation carried out after a visual control only.

The operation described above should be repeated progressively (by moving forwards the disk by about 12° at a time) and modifying every time, if necessary; the fuel/air ratio during the entire modulating run.

Make sure that the increase in fuel delivery occurs gradually and that maximum delivery is reached at the end of the modulation run. This is necessary in order to ensure that modulation functions with good graduality. The position of the screws that command the fuel may need to be modified in order to obtain the graduality required. Maximum delivery is obtained when the return pressure is about 2 ÷ 3 bar less than the delivery pressure (normally 20 ÷ 22 bar).

For a correct Fuel/air ratio, the percentage of Carbon Dioxide (CO<sub>2</sub>) should increase with the increase

delivery (from a minimum of 10% at minimum delivery to a maximum of 13% at maximum delivery).

We advise against exceeding 13% of CO<sub>2</sub> to avoid operating with a rather limited excess of air which would cause a considerable increase in smoke opacity due to unavoidable circumstances (a variation in the atmospheric pressure; presence of dust particles in the fan's air ducts, etc.).

Smoke opacity depends on the type of fuel utilized (the most recent provisions indicate that it should not exceed n. 2 of the Bacharach Scale).

We advise, if possible, maintaining smoke opacity below n. 2 of the Bacharach Scale even if, as a consequence, the CO<sub>2</sub> value is slightly lower.

The lower smoke opacity dirties the boiler less and therefore its average yield is normally higher even when the CO<sub>2</sub> value is slightly inferior.

It should be remembered that, in order to regulate properly, the water in the system should be at the right temperature and the burner should have been operating for at least 15 minutes. If the appropriate instruments are not available, judgement can be based on the colour of the flame.

We advise regulating in such a way as to obtain a flame bright orange in colour.

Avoid a red flame with smoke in it, or a white flame with an exaggerated excess of air.

After having checked the fuel/air regulation, tighten the locking screws of the adjustable screws.

19) Now check if the modulation is functioning correctly in the automatic mode by moving the AUT - 0 - MAN switch to the "AUT" position and the MIN - 0 - MAX switch "0".

In this way the modulation is connected only by means of the automatic control of the boiler probe if we have a modulating burner or by means of a command coming from 2° stage thermostat or pressure switch if we have a two progressive stage burner.

20) Check the efficiency of the flame detection device (photoresistance).

The photoresistance is a flame control device and, if the flame should be extinguished during operations, it must be capable of intervening (this control should be made at least one minute after start up). The burner should be capable of blocking itself (shut down), and remaining so; if the flame does not appear regularly during the start up phase within the time limit preset on the control box.

The shut down causes an immediate interception of the fuel, the burner comes to a standstill and the red warning light comes on. To check the efficiency of the photoresistance and of the shut down system, proceed as follows:

a) start up the burner

b) after about one minute, extract the photoresistant cell by pulling it out of its seat and simulate flame failure (using a hand or a rag to close the window in the photoresistance support). The flame should be extinguished.

c) Keep the photoresistant cell in the dark and the burner will start up again but, as the photoresistance does not see the light, the burner will go to shut down within the time preset on the control box's programme.

The control box can only be unblocked by pressing manually on the appropriate push-button. To check the efficiency of the shut down device; carry out this control at least twice.

21) Check the efficiency of the boiler's thermostats or pressure switches (this operation should stop the burner.)

### **USING THE BURNER**

The burner are fully automatic and, therefore, do not require any regulation. The "lockout" position is the fail-safe position the burner automatically reverts to whenever a part of the burner or of the system fails. It is, therefore, advisable to make certain there are no problems or malfunctions in the heating unit before "resetting" the burner. The unit can also be locked out for temporary irregularities. If reset, the burner should function normally. On the other hand, if the unit keeps cutting out (3-4 times in a row), do not insist. Instead, call the authorized Service Center in your area who will remedy the situation. The burner can remain in the lockout position indefinitely.

### **MAINTENANCE (HEAVY- OR LIGHT-OIL BURNER)**

If the burner is installed in an adequate environment and a suitable fuel is used the unit will not require frequent maintenance. Obviously it is necessary to periodically clean the line filter, the filter inserted in the pipe between the preheater and the nozzle, the combustion head, disk and electrodes.

In order to clean the combustion head, it first needs to be dismantled. Care should be taken during reassembly to centre the combustion head exactly and check the correct position of electrode/s and disk.

The frequency of these operations is determined by on-site experience as it principally depends on the fuel used and on the type of installation (intermittence in operation).

We advise carrying making your initial checks on a weekly basis and then act according to the results.

Although not directly under our responsibility, we also recommend checking the cleanliness of the boiler whenever the burner is being checked.

To clean the nozzle its components must be disassembled and then any heavy oil must be washed away with solvent (trichloroethylene, oil, gas oil, benzene). If a stronger action is necessary, use compressed air and an appropriately shaped piece of wood (stick or chip) or plastic. Do not use metal tools which could damage the nozzle beyond repair. In particular, make certain that the outlet hole, the slots of the turbulence chamber and the small fuel return holes on the bottom of the turbulence chamber are clean. If evident signs of wear are noted, the whole nozzle must be replaced.

Clean the flame sensor (light-dependent resistor or UV photo-cell) as required.

**HYDRAULIC DIAGRAM TO THE BURNERS SC... SERIES OPERATING WITH LIGHT OIL OR HEAVY OIL WITH MAX NOMINAL VISCOSITY 5 °E AT 50 °C**

- 1 - Filter
- 2 - Circulation pumps (one spare)
- 3 - Burner pushing central station
- 4 - By pass (normally closed)
- 5 - Pressure regulator adjustable from 0,5 to 2 bar
- 6 - Pressure gauge (0 ÷ 4 bar)
- 7 - Main tank
- 8 - Oil heating at steam or at hot water in order to keep, also during a short period of non operation, a temperature value sufficient for the flow in the piping

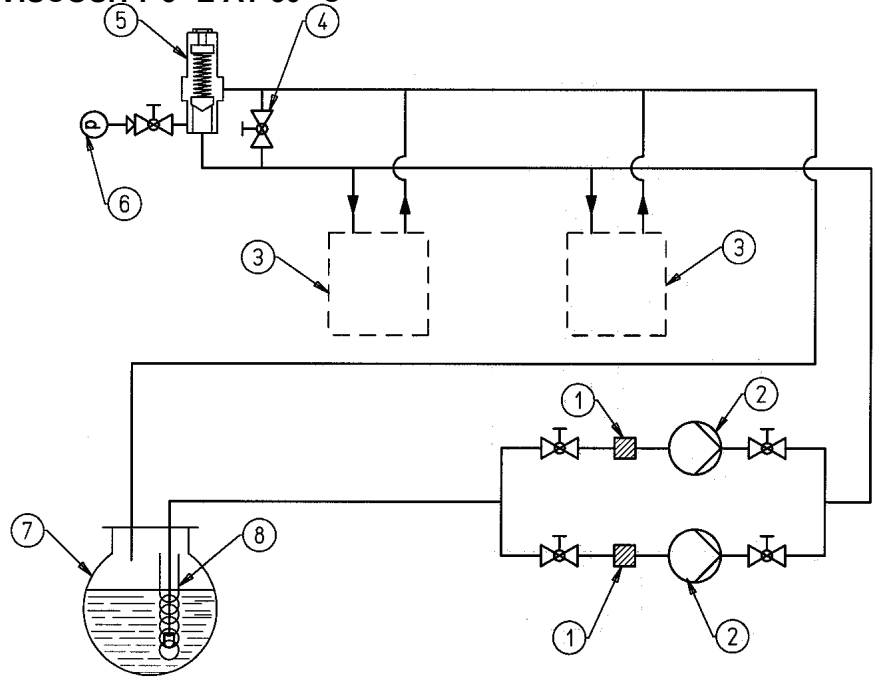

**COMPREHENSIVE DIAGRAM FOR LIGHT OIL CIRCUIT OF BURNER SC 14..**

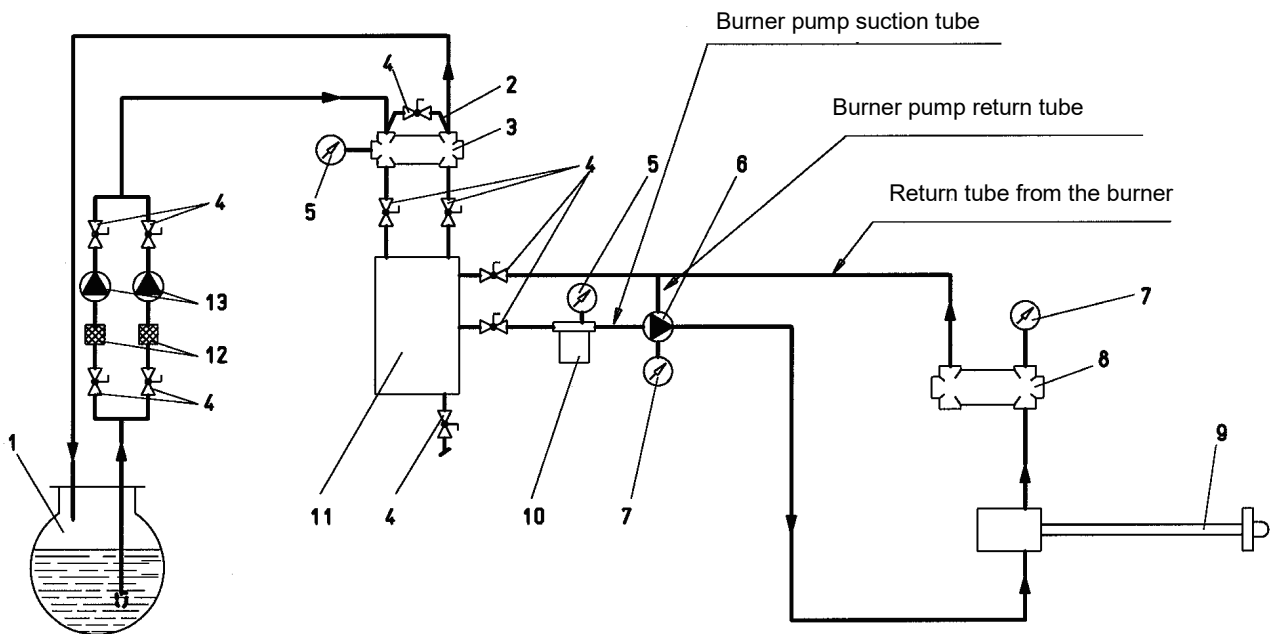

- 1 - Main tank
- 2 - Possible by-pass of pressure regulator
- 3 - Possible low pressure control valve
- 4 - Manual on-off ball valve
- 5 - 0 ÷ 3 bar pressure gauge
- 6 - Burner feed pump with built - in pressure regulator (20 ÷ 22 bar)

- 7 - 0 ÷ 30 bar pressure gauge
- 8 - Return pressure regulator (min. 5 ÷ 7 bar - max. 18 ÷ 20 bar)
- 9 - Atomizing unit with magnet
- 10 - Self-cleaning filter
- 11 - Degassing tank Ø 195 x 530
- 12 - Filter
- 13 - Circulation pump

**DIAGRAM FOR DANFOSS PUMP MODEL KSVB**

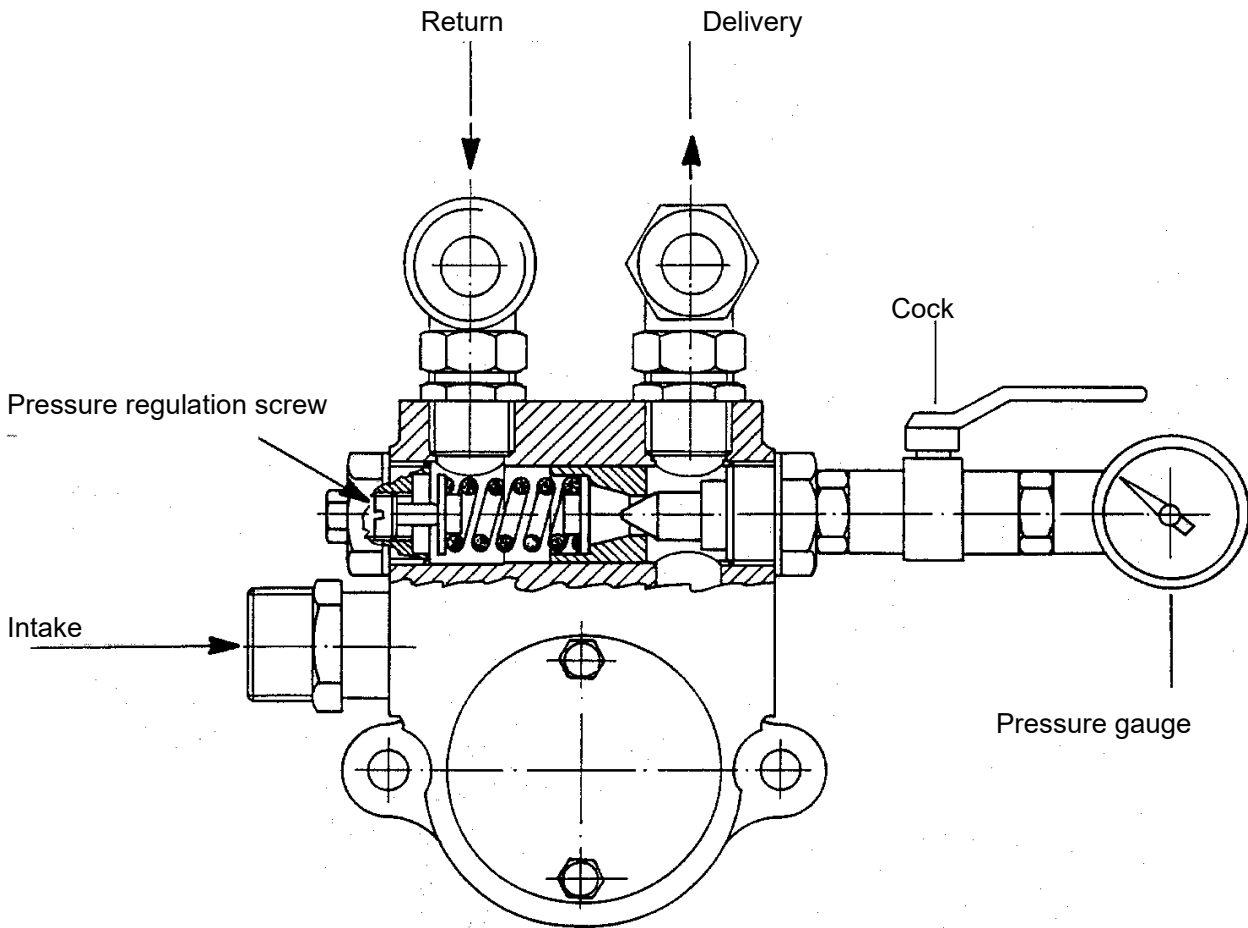

Nozzle ID:  
Flow rate in kg/h  
Spray angle (30° - 45° - 60° - 80°)  
Flow ratio (1/3 = B3 - 1/5 = B5)

Fuel outlet

Air turbulence chamber

Fuel inlet

Fuel return

Viton O-ring (oil and temperature resistant)

Fuel return holes

N.B. For the nozzle to operate properly, its "return" section must never be completely closed.  
This is achieved by regulating when the burner is started up for the first time. In practice, when the nozzle is operating at the maximum flow rate, the difference in pressure between the "delivery" (pump pressure) and "return" (pressure at the return pressure regulator) pressures (running to and from the nozzle) must be at least 2÷3 bar.

Example:	Pump pressure	20 bar	Pump pressure	22 bar
	Return pressure	20 - 2 = 18	Return pressure	22 - 3 = 19 bar
		20 - 3 = 17		22 - 2 = 20 bar

### COMBUSTION HEAD SETTING

Air passage is full opened. When combustion head is pulled, air passage will increase

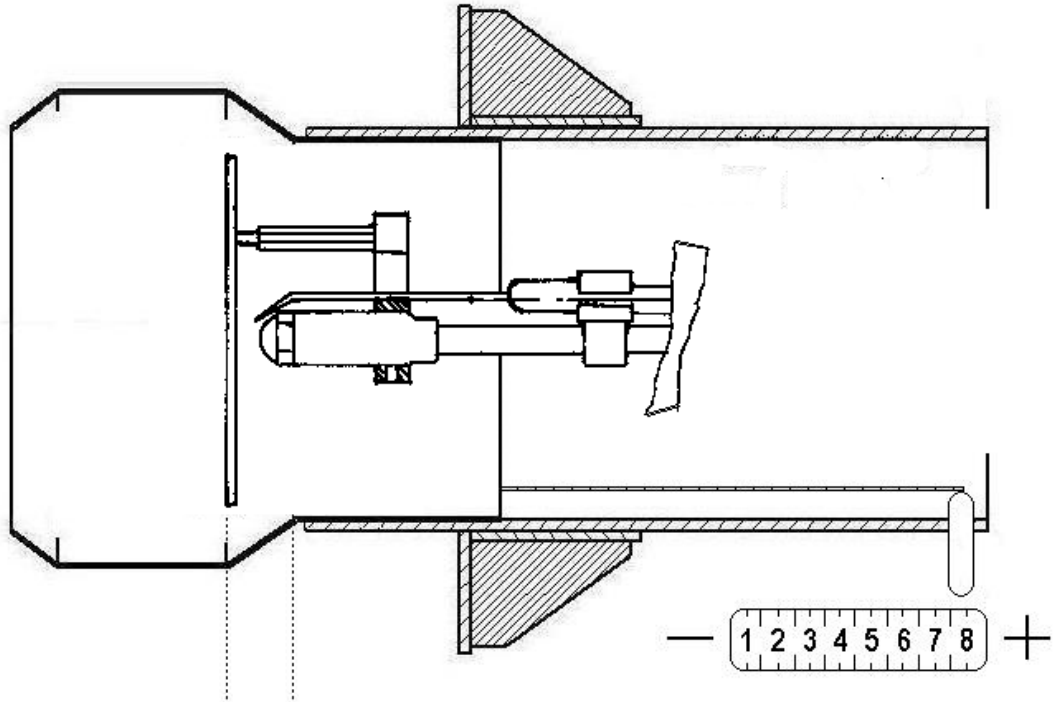

Air passage is totally closed. When combustion head is pushed, air passage will decrease.

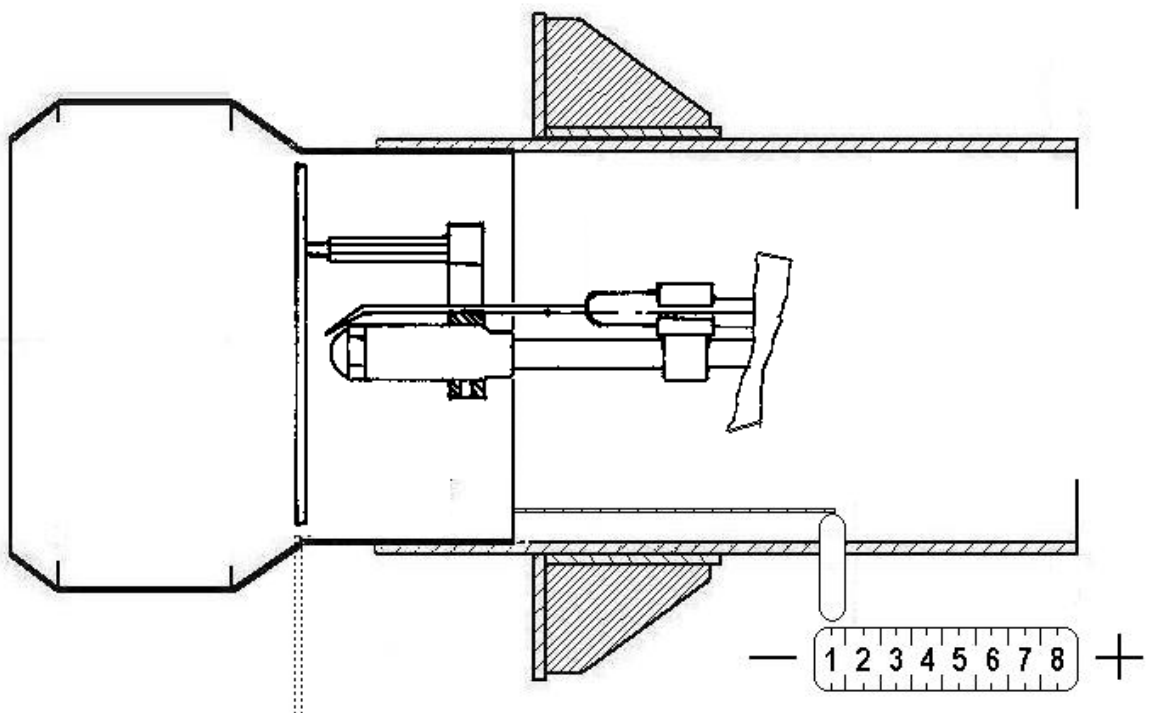

**MIN. AIR PASSAGE**

### IGNITION ELECTRODE AND MIXER DISC

Position of ignition electrode and mixer disc is important to provide the regular combustion. Distance between ignition electrode and pilot gas nozzle and distance between mixer disc and nozzles must be adjusted to dimensions specified.

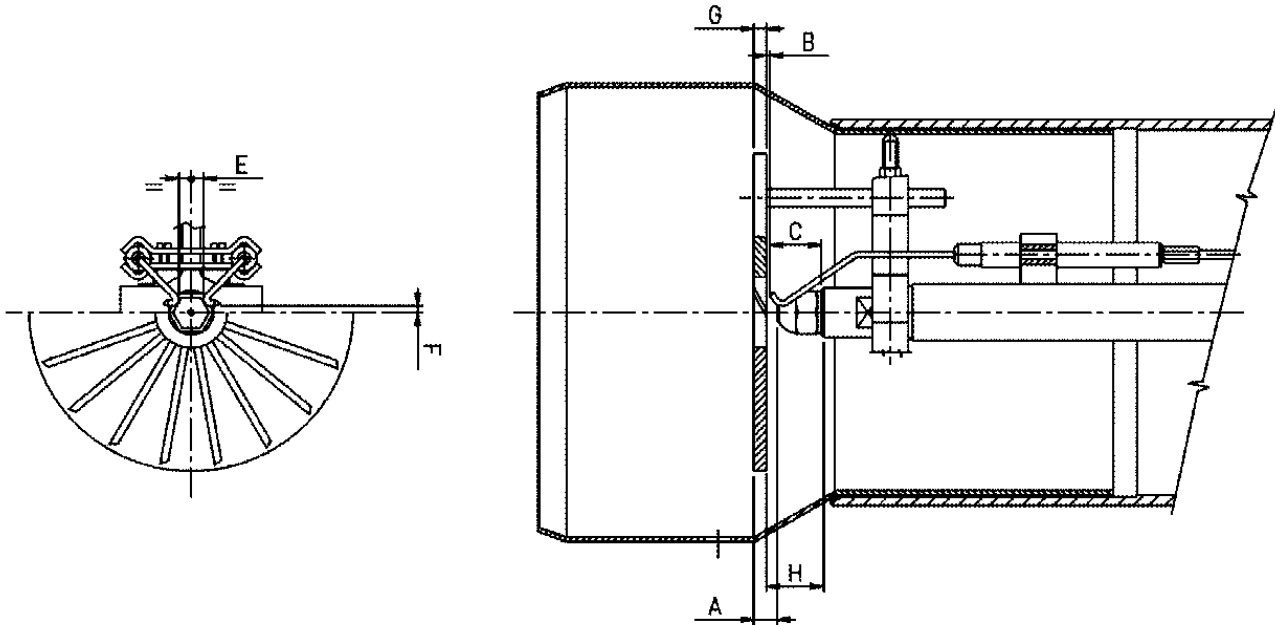

BURNER MODEL	A	B	C	E	F	G	H
SC 10.1	19	5	30	3	15	5	29
SC 10.2	19	5	30	3	15	5	29
SC 10.3	19	5	30	3	15	5	29
SC 12.1	23	6	30	3	15	6	34
SC 12.2	23	6	30	3	15	6	34
SC 14.1	26	8	30	3	15	6	36
SC 14.2	26	8	30	3	15	6	36

# Selkoc

Isıtma & Soğutma Otomasyon San. Tic. Ltd. Şti.

+90 (555) 994 13 62  
+90 (212) 501 48 54 - 55  
+90 (212) 501 48 57

info@selkoc.com.tr  
satis@selkoc.com.tr  
export@selkoc.com.tr

İsmetpaşa Mah. Hisar Sk. No:20/53-59  
Üstün İş Merkezi Bayrampaşa / İstanbul / Turkey